

MOTOR SPECIFICATION SHEET

MODEL : SB-JR 1HP 4P (LT)

USED FOR : STANDARD

DESCRIPTION	DETAIL				
PHASE	3				
MODEL NAME	SB-JR				
RATED OUTPUT, HP (kW)	1 (0.75)				
POLE	4				
CODE	MEATH CODE : 1M002B-400075JRFW0				
OUTLINE DRAWING NO.	ONM84O184-*				
RATED VOLTAGE (V)	220	380	415	220	440
RATED FREQUENCY (Hz)	50	50	50	60	60
RATED CURRENT (A)	3.5	2.0	2.3	2.9	1.7
RATED SPEED (min ⁻¹)	1400	1400	1410	1700	1720
THERMAL CLASS	130(B)				
RATING	S1 (CONTINUOUS)				
ENCLOSURE CONSTRUCTION	DRIP-PROOF				
DEGREES OF PROTECTION	IP22				
METHOD OF COOLING	IC01				
FRAME NO.	80M				
WEIGHT (kg)	10				
STANDARD	IEC 60034-1, JEC-2137-2000				
INSTALLATION	FOOT MOUNTED				
ROTATION	CCW (VIEWED FROM SHAFT END)				
BEARING	LOAD SIDE : 6204ZZ				
	OPPOSITE SIDE : 6203ZZ				
BEARING GREASE	UREA GREASE				
NOISE (dB.A)	58				
VIBRATION	V15				
CIRCUMSTANCE CONDITION	AMBIENT TEMPERATURE : -20 ~ +40°C				
	AMBIENT HUMIDITY : 85%RH OR LESS				
	ABOVE SEA LEVEL : 1000m OR LESS				
	ENVIRONMENT : NO BURSTING/EROSIVE GAS OR VAPOR				
COLOR	MUNSELL N5.5 (GRAY)				
TERMINAL BOX	NO. OF LEAD WIRES : 6				
	SOURCE CONNECTION : LEAD WIRES				
INSULATION RESISTANCE	BY DC 500V MEGGER - ≥100MΩ				
DIELECTRIC TEST	AC 50Hz 1800V - 1min. (Based on rated voltage 380V)				
SHAFT SWING	≤0.03mm				
MATERIAL	FRAME : STEEL PLATE				
	BRACKET : ALUMINIUM				
	SHAFT : CARBON STEEL				
	STATOR CORE : ELECTRICAL STEEL				
	WIRE : ENAMELLED COPPER MAGNET WIRE				
	INSULATOR : POLYESTER FILM				
	VARNISH : EPOXY DENATURALIZATION POLYESTER				
	ROTOR CORE : ELECTRICAL STEEL				
	CONDUCTOR : ALUMINIUM				
	TERMINAL BOX : STEEL PLATE				
	PAINTING : ALKYD-NITROCELLULOSE RESIN				
PRODUCTION COUNTRY	THAILAND				

Specifications subject to change without notice.

SPECIFICATION SHEET NO.				
SS-M-8560-A				

MODEL SB-JR THREE PHASE INDUCTION MOTOR OUTLINE DRAWING

DRIP-PROOF TYPE
DEGREES OF PROTECTION IP22

CUSTOMER _____
USER _____
FOR _____
CUSTOMER'S ORDER NO. _____
QUANTITY _____
MFG. ORDER NO. _____

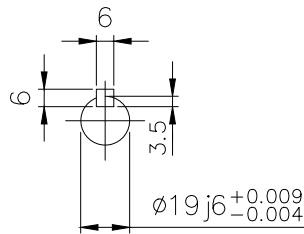
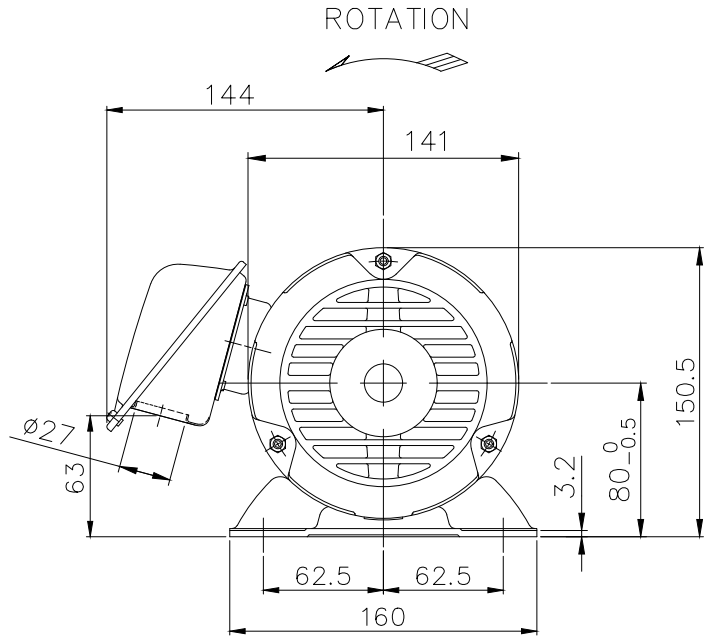
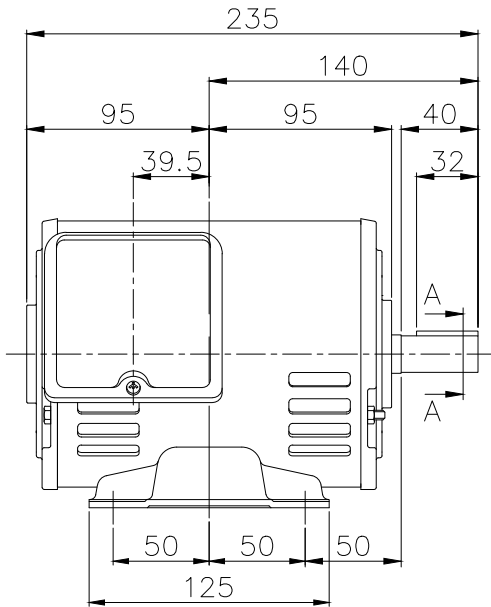

SECTION A-A

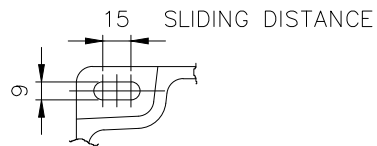

FRAME FOOT AS VIEWED FROM BELOW

YOUR ORDER	FRAME SIZE	RATING	TH. CLASS	AMB. TEMP.	BEARINGS		COLOR	DIRECTION OF ROTATION	NO. OF LEAD WIRES	REMARKS
					LOAD SIDE	OPP. SIDE				
	80M	S1 (CONT.)	130(B)	40°C	6204ZZ	6203ZZ	GRAY (MUNSELL N5.5)	CCW	6	

YOUR ORDER	OUTPUT		POLES	VOLT	HERTZ	REMARKS
	HP	KW				
	1	0.75	2	220/380/415	50	LT
				220/440	60	
	1	0.75	4	220/380/415	50	LT
				220/440	60	
	1/2	0.4	6	220/380/415	50	LT
				220/440	60	

MITSUBISHI ELECTRIC AUTOMATION (THAILAND) CO., LTD.

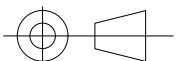

DIMENSION IN mm.

SCALE : NTS

OUTLINE DRAWING NO.

0 N M 8 4 0 1 8 4

REV.

*